

# 5. FLOOR INSTALLATION SYSTEMS

## TABLE OF CONTENTS

Tacker Sheet System. . . . .	pg32
RAUFIX/Railfix System . . . . .	pg37
Diffusion Plate System . . . . .	pg42
Floating Floor System . . . . .	pg47
Sprung Floor System. . . . .	pg52

**REHAU also supplies the following system:**

- Industrial/Structural Systems.

For further information please contact your local REHAU Sales Office.

## 5. TACKER SHEET SYSTEM



This system saves significant time and costs during the installation process by combining previously separate installation steps into one.

When compared to a standard fixing rail system, the steps of:

- Rolling out a polyethylene foil on top of the EPS boards
- Fixing the rails to the EPS boards are no longer required.

In addition to this, the Tacker Sheet system also allows more flexibility in circuit patterns.

Patterns, such as the reverse spiral are easier and quicker to install. The system has clear advantages, when circuits are installed in areas with drains, pillars, alcoves etc, since the pipe can now be easily laid around such obstacles.

The REHAU range of RAUTHERM pipe in sizes 16mm x 1.5mm and 20mm x 1.9mm are fully compatible with the Tacker Sheet system.

# 5. FLOOR INSTALLATION SYSTEMS

## COMPONENT DESCRIPTION

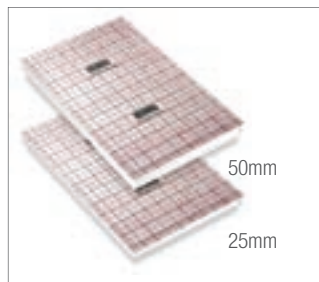
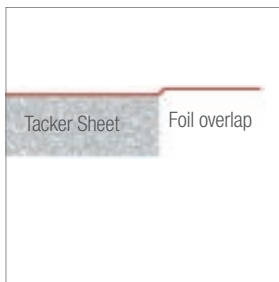

### Tacker Sheets

The Tacker Sheet is made out of standard expanded polystyrene grades already well established within the building industry. They comply with the relevant industry standard and are CFC free.

Each board is laminated with a fabric reinforced foil made from polyethylene. A grid system is printed onto the clear foil allowing the installer to quickly determine the appropriate pipe spacing during the installation. The fact, that the foil is water resistant, together with the foil overlaps on two adjacent sides of each board ensure, that when the joints are sealed with tape, no water from the screed will penetrate through to the insulation.

Tacker Sheet is available in EPS70, EPS100 and EPS 150 grades in both 25mm and 50mm thickness. Standard Fire Class is F (according to BS EN 13163).

### Tacker Staples

REHAU Tacker Staples are available in two specifications – grey staples for 16mm pipes and black staples for 20mm pipes. The two size specifications and innovative hook design ensure secure fixing of the pipes onto the Tacker Sheet. The latter ensures maximum retention of the staples by the foil's fabric reinforcement, thereby preventing the pipe from lifting during the screeding process.

When fixing the pipe, staples should be positioned at maximum intervals of 400mm centres of pipe length. If Tacker Staples are set wrongly and are consequently pulled out, it is crucial to tape over the grid holes punched by the staples.

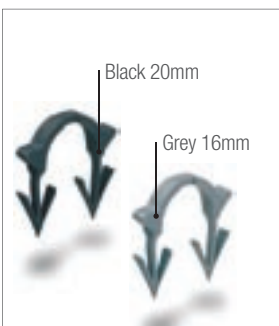

The staples are heated and attached to form magazines of 30 staples each. The usual securing strap and any impairment of the setting procedure via gluing with remains of the securing strap does not apply.

REHAU Tacker Staples should only be fixed into the Tacker Sheet with the REHAU Tacker staple gun.

### REHAU Multi Stapling Unit

The REHAU multi stapling unit is used for setting RAUTAC staples/ REHAU staples on the REHAU stapling panels. A clip fixing tool is still required for further processing of both staples.

The staples magazines are inserted into the magazine rod shaft.

A feeding aid increases the pressure on the staples and ensures proper setting of the staples and thus short installation times.



Even downward pressure on the ergonomically-shaped actuator handle inserts the staples into the cloth film of the REHAU stapling panels. When the actuator handle is released, it returns to its original position via a spring, and the setting procedure can be repeated straight away.

### Upgrade set for RAUTAC stapling unit and REHAU stapling unit

To use the heat-formed staples magazine with the RAUTAC stapling unit, the clip fixing tool must be equipped with an upgrade set. You can obtain this at your respective REHAU sales office.

In just a few steps, the upgrade set is mounted to the stapling unit. Installation instructions are included with each upgrade set for this purpose.

A feeding aid which applies pressure to the staples magazine is included with the upgrade set.

- Attach the feeding aid to the full magazine rod to ensure even feeding of the staples and optimum loading pressure.

The staples are heated and attached to form magazines of 30 staples each. The usual securing strap and any impairment of the setting procedure via gluing with remains of the securing strap does not apply.

# 5. TACKER SHEET SYSTEM INSTALLATION INSTRUCTIONS

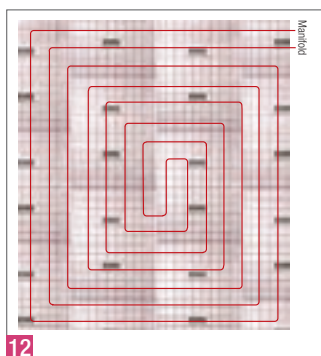
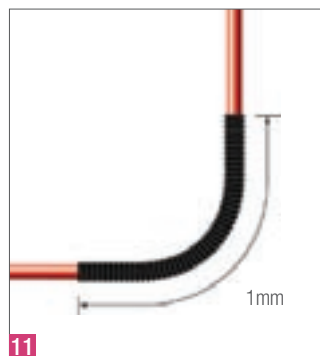
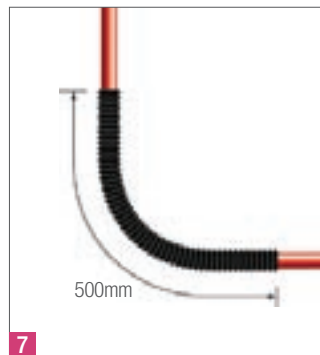
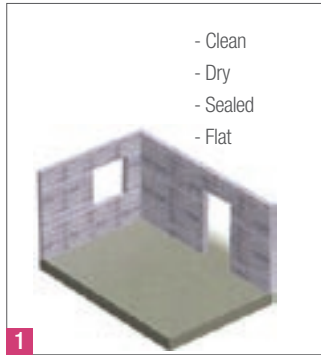

**Step 1** - Make sure site requirements for installing underfloor heating are met: rooms cleared, installation area dry, sealed to the elements, flat even floor and surface free of irregularities.

**Step 2** - Fit REHAU Edge insulation around perimeter and internal walls, columns, drains and door frames ensuring a 50mm overlap at joints (insulation already comes with self adhesive tape on back).

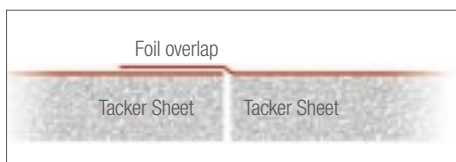

**Step 3** - Lay Tacker Sheet boards ensuring the following:

- Printed foil faces
- Grid lines up across the joints
- Stagger the joints as in a brick wall
- Each joint is covered with a foil overlap (Tacker Sheet already comes with a foil overlap on two adjoining sides)
- Tacker Sheets are butted tightly up against each other.

**Step 4** - Tape all joints to ensure no water from the screed passes underneath the boards.

**Step 5** - Remove cover from adhesive tape from the foil on edge insulation and fix it to Tacker Sheets.

**Step 6** - Fix manifold and retaining rail to wall or into cabinet.

**Step 7** - Cut a short piece of corrugated sleeve (at least 0.5m long) and slide it over the pipe end. Sleeve is to protect pipe from shearing where it enters the screed.

**Step 8** - Connect REHAU RAUTHERM pipe to manifold using REHAU pipe connection unions.

**Step 9** - Start laying the circuit by simply stapling the RAUTHERM pipe onto the Tacker Sheet using the correct sized REHAU Tacker staples and staple gun (see table overleaf for details). Set staples at a maximum interval of 400mm.

To push a staple into the insulation, simply push down the handle of the gun fully and allow it to travel back up again completely, before pushing in the next staple.

- Always ensure there is a sufficient number of staples on the carrier to allow correct feeding of the staples into the staple gun
- If staples are pulled out of the Tacker Sheet, tape over the punched holes to keep top surface water resistant.

**Step 10** - When installing pipe in door frames, holes through walls or across planned expansion joints, always put on a section of corrugated sleeving in this area to allow free movement of pipe. Sleeving can be split along the length and clipped over the pipe.

**Step 11** - Before connecting return to manifold, slide on another 0.5m long corrugated sleeve section.

**Step 12** - Install remaining circuits in the same way as detailed in steps 7. to 11.

- For commissioning see page 72.

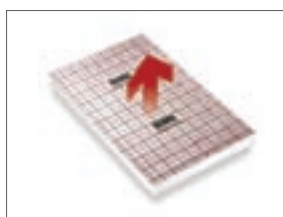

**IMPORTANT**  
Printed foil facing upwards



**IMPORTANT**  
Use correct size of staples

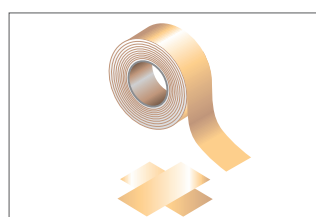

**IMPORTANT**  
Tape all joints

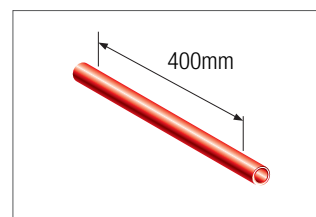

**IMPORTANT**  
Use staples at least every 400mm

## Component Selection Table

Components	16mm RAUTHERM Pipe Art. No. 136430	20mm RAUTHERM Pipe Art. No. 136450	Average Quantity
<b>Tacker Staples</b> Art. No. 240221, grey colour Art. No. 262373, black colour	Y N	N Y	2.5 per metre pipe 2.5 per metre pipe
<b>Tacker Gun Multi</b> Art. No. 227835	Y	Y	
<b>Tacker Sheets</b> Complete range	Y	Y	0.35 sheets per m <sup>2</sup>
<b>Edge Insulation</b> Art. No. 264411	Y	Y	Length of perimeter
<b>Corrugated Sleeve</b> Art. No. 137140 Art. No. 137150	Y N	N Y	1m per manifold port 1m per manifold port
<b>REHAU Tape</b> Art. No. 265942	Y	Y	1.25m per m <sup>2</sup>
<b>REHAU Tape Dispenser</b> Art. No. 261959	Y	Y	
<b>REHAU EPS Cutter</b> Art. No. 249632 Art. No. 24652, spare cutter blades	Y Y	Y Y	

## Technical Data

	EPS 70 25mm	EPS 70 50mm	EPS 100 25mm	EPS 100 50mm	EPS 150 25mm	EPS 150 50mm
REHAU Art. No.	238243	238233	233504	233494	286859	286864
Dimensions in mm (Length x Width x Thickness)	2400x1200x25	2400x1200x50	2400x1200x25	2400x1200x50	2400x1200x25	2400x1200x50
Make-up	Single Board	Foldable Board	Single Board	Foldable Board	Single Board	Foldable Board
Thermal conductivity	0.038 W/mK	0.038 W/mK	0.036 W/mK	0.036 W/mK	0.035 W/mK	0.035 W/mK
Compression strength 10%	>70 kPa	>70 kPa	>100 kPa	>100 kPa	>150 kPa	>150 kPa
Breaking strength	>115 kPa	>115 kPa	>150 kPa	>150 kPa	>200 kPa	>200 kPa
Designation to EN 13163 E	EN 13163-T1-L1 W1-S2-P3-DS(80,-)1	EN 13163-T1-L1 W1-S2-P3-DS(80,-)1	EN 13163-T1-L1 W1-S2-P3-DS(80,-)1	EN 13163-T1-L1 W1-S2-P3-DS(80,-)1	EN 13163-T1-L1 W1-S2-P3-DS(80,-)1	EN 13163-T1-L1 W1-S2-P3-DS(80,-)1
Fire class to EN 13163 E	F	F	F	F	F	F

## Typical Floor Structure

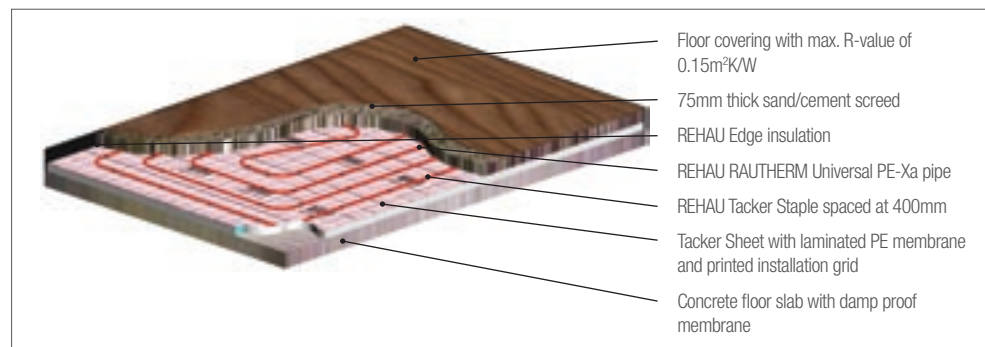

## 5. RAUFIX/RAILFIX SYSTEM



This system ensures that uniform circuit patterns are easily achieved and simplifies the installation process in larger areas.

The underfloor heating circuits can be laid in the double meander pattern, which gives an even spread of heat by alternating the flow and return pipes.

The REHAU range of RAUTHERM pipe in sizes 16mm x 1.5mm and 20mm x 1.9mm are fully compatible with the RAUFIX/Railfix system.

REHAU also offer the Railfix System. This system is an alternative to RAUFIX. The installation method follows that of RAUFIX, with the exception of using Railfix rails rather than RAUFIX. Railfix is supplied in 3m and 4m lengths for 16mm or 20mm pipe sizes.

# 5. RAUFIX/RAILFIX SYSTEM

## COMPONENT DESCRIPTION



### RAUFIX Rail

The RAUFIX rail is manufactured from Polypropylene and its unique pipe clip design makes it universal for both REHAU pipe sizes - 16mm and 20mm.

The function of the rail is to secure the underfloor heating circuits in the planned pattern prior to screeding.

The RAUFIX rails are supplied in 1m lengths and there are two variants:

- With barb:  
Allows the rail to be fixed directly on the EPS floor insulation
- Without barb:  
When fixing, extra staples are needed.

It is placed on top of the polyethylene membrane and fixed securely onto the EPS floor insulation by using the plastic staples or barbs.

The rails must be placed 800mm from walls and obstacles and spaced at 1m centres.

The RAUFIX rail also features an integrated clip which makes connecting rails together simple and easy without the need of a tool.

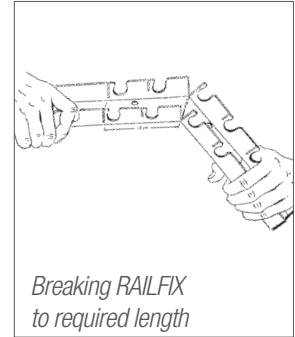
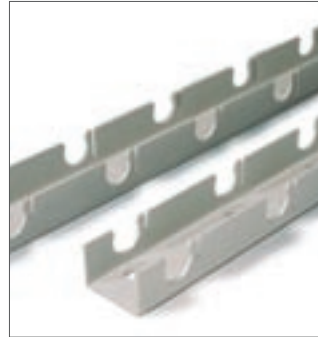

### Railfix Rail

The Railfix rails are manufactured from recycled polymer and are available for both REHAU RAUTHERM pipe sizes - 16mm and 20mm.

The Railfix rail is notched at 50mm intervals to accept the pipe and is placed 800mm from walls and obstacles, spaced at 1m centres and must be fixed with staples every 400mm.

The rails are manufactured with a break point at 100mm centres to facilitate easy installation.

### Staples

The REHAU RAUFIX/Railfix staples are available in two sizes - 50mm and 40mm. The size of staple used will depend on the thickness of the EPS floor insulation. For 25mm EPS floor insulation the 40mm staples should be used and pushed in through the rail at alternating angles. For 50mm EPS insulation it is recommended to use the 50mm staples.

Trim offs from the rails can also be used to fix the pipe bends to the EPS floor insulation.

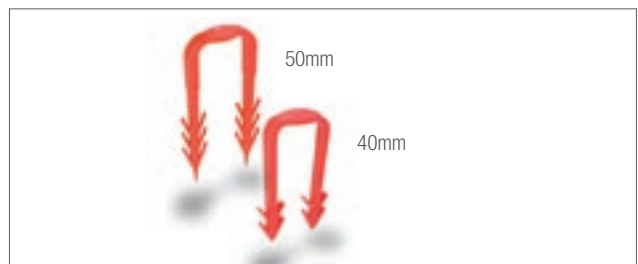

# 5. RAUFIX/RAILFIX SYSTEM

## INSTALLATION INSTRUCTIONS

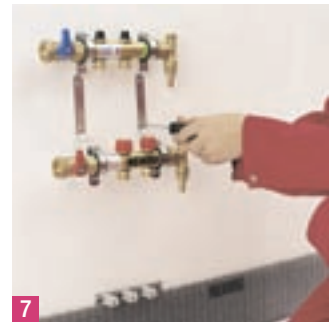
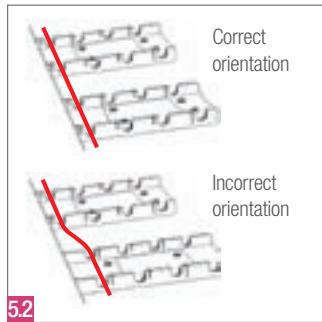
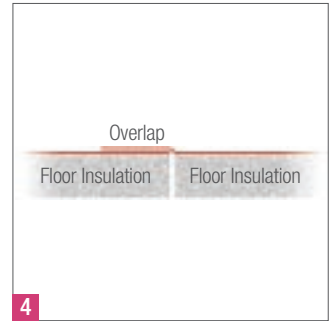
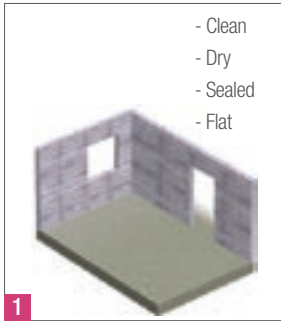

**Step 1** - Make sure site requirements for installing underfloor heating are met: rooms cleared, installation area dry, sealed to the elements, flat even floor, and surface free of irregularities.

**Step 2** - Fit REHAU Edge insulation around the perimeter and internal walls, columns, drains and door frames ensuring a 50mm overlap at joints (insulation already comes with self adhesive tape on the back).

**Step 3** - Lay insulation ensuring the following:

- Stagger the joints as in a brick wall.
- Insulation boards are butted tightly up against each other.

**Step 4** - Lay polyethylene membrane over floor insulation, ensuring that:

- It is placed up the walls, above the finished floor height
- The membranes overlap each other by 80mm
- The membrane must be watertight when used with an Anhydride (flow) screed, by taping the joints and the edge insulation.

**Step 5.1 - RAUFIX** - Fix rails to the EPS floor insulation using staples every 400mm. Rails must be fixed 800mm from walls and obstructions to allow for the bending radius of the pipe. The remainder of the area should have rails laid at 1m centres.

**Step 5.2 - Railfix** - Fix rails to the EPS floor insulation using staples every 400mm. Keep orientation of rail the same to ensure correct pipe spacing.

**Step 6** - In areas of pipe bends/returns, rail trim offs can also be used to fix the pipe bends directly to the floor insulation and to ensure uniform spacing.

**Step 7** - Fix manifold to wall or into cabinet and fix retaining rail.

# 5. RAUFIX/RAILFIX SYSTEM

## INSTALLATION INSTRUCTIONS

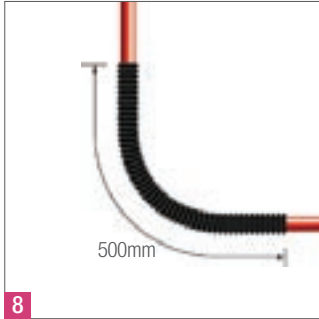

8



9



10



11



12

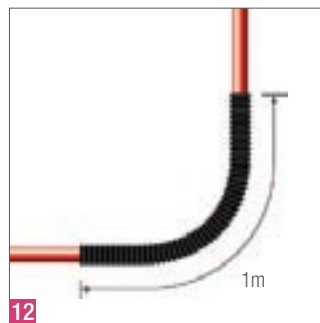

12

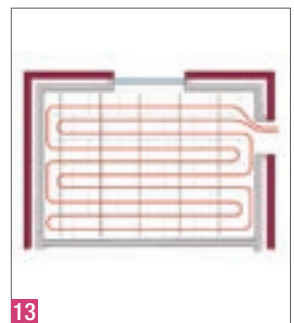

13

**Step 8** - Cut a short piece of corrugated sleeve (at least 0.5m long) and slide it over the pipe end. Sleeve is to protect pipe from shearing where it enters the screed.

**Step 9** - Connect REHAU RAUTHERM pipe to the manifold using REHAU pipe connecting unions.

**Step 10** - Start laying the circuit by simply “snapping” the pipe into the RAUFIX/Railfix rails. The circuit is laid in the double meander pattern as per the underfloor heating design.

**Step 11** - When installing pipe in door frames, holes through walls or across planned expansion joints, always put on a section of corrugated sleeving in this area to allow free movement of pipe. Sleeving can be split along the length and clipped over the pipe.

**Step 12** - Before connecting return to manifold, slide on another 0.5m long corrugated sleeve section.

**Step 13** - Install remaining circuits in the same way, as detailed in steps 8 to 12.



**IMPORTANT**  
Rails to be spaced evenly at 1m and 0.8m from walls

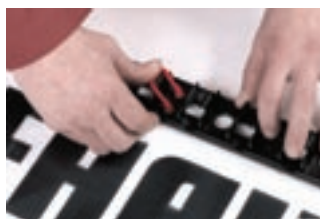

**IMPORTANT**  
40mm Staples set at an angle for 25mm insulation

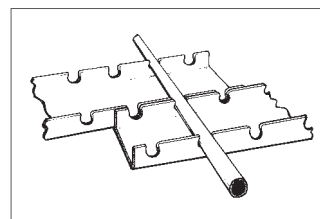

**IMPORTANT**  
Railfix: End must overlap when extending rails

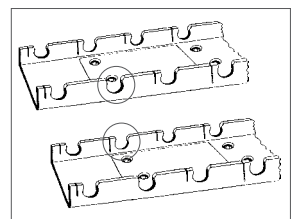

**IMPORTANT**  
Railfix: Keep orientation of rail the same to ensure correct pipe spacing

### Component Selection Table

Components	16mm Pipe Art. No. 136430	20mm Pipe Art. No. 136450	Average Quantity
<b>RAUFIX Staples</b> Art. No. 268118, 40mm Art. No. 259268, 50mm	Y Y	Y Y	3 pieces per m <sup>2</sup> 3 pieces per m <sup>2</sup>
<b>RAUFIX Rail</b> Art. No. 244248 with barbs Art. No. 240241	Y Y	Y Y	1 m per m <sup>2</sup> 1 m per m <sup>2</sup>
<b>Edge Insulation</b> Art. No. 264411	Y	Y	length of all perimeter walls
<b>Corrugated Sleeve</b> Art. No. 137140 Art. No. 137150	Y N	N Y	1 m per manifold port 1 m per manifold port
<b>REHAU Adhesive Tape</b> Art. No. 265942	Y	Y	1 m per m <sup>2</sup>
<b>REHAU Tape Dispenser</b> Art. No. 261959	Y	Y	-
<b>Polyethylene Membrane</b> Art. No. 256054	Y	Y	1.3m per m <sup>2</sup> floor

### Technical Data

Polystyrene Insulation	40mm Staple Art. No. 268118	50mm Staple Art. No. 259268
<b>EPS 70 25mm</b> Art. No. 264195	Y	N
<b>EPS 70 50mm</b> Art. No. 264205	N	Y
<b>EPS 100 25mm</b> Art. No. 264175	Y	N
<b>EPS 100 50mm</b> Art. No. 264185	N	Y

### Typical Floor Structure

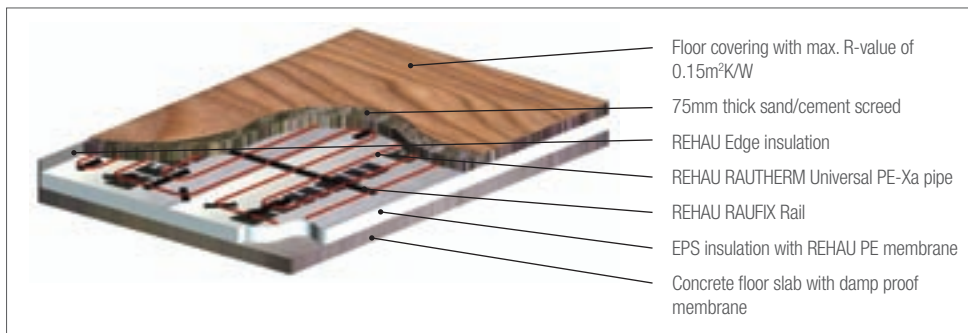

## 5. DIFFUSION PLATE SYSTEM



The REHAU Diffusion Plate system has been designed for timber joist floor applications.

The system uses aluminium plates to diffuse the heat over the floor area. Due to the high conductivity of the plates the reaction time compared to traditional screed systems is reduced.

It is installed into the building prior to wiring and plumbing.

Care must be taken when installing this system in open joists, please refer to the relevant Health and Safety guidelines.

The Diffusion Plate system utilises the REHAU RAUTHERM universal pipe 16mm x 1.5mm.

**Because the heat transfer of this system is different to a standard screed system, standard design software such as HT2000 cannot be used.**

# 5. DIFFUSION PLATE SYSTEM

## COMPONENT DESCRIPTION

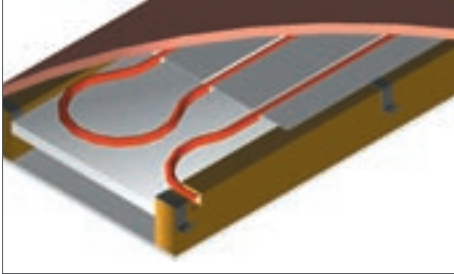

### Diffusion Plates

The REHAU aluminium heat diffusion plates are designed for the use of underfloor heating in a first floor joist floor application. They are manufactured from 0.8mm thick aluminium and are supplied in 1m lengths (½ metre lengths available on request) either as:

- Two channel
- Three channel (to be used in bathrooms/en-suites where floor area is limited).

Both plates can be easily trimmed to length by cutting a 'V'-shaped notch into every channel using a hacksaw. Ensure any rough edges are removed by using a rat tailed file before fitting any pipes.

The pipes are tightly gripped within the plates ensuring maximum heat transfer. Due to its highly conductive nature, the aluminium plates diffuse the heat evenly over the plate area. The heat is then transferred through the floor surface into the room. Standard 25mm EPS 70 floor insulation (or alternative i.e. fibre glass wool) must be installed directly below the plates to reduce heat loss.

### Joist Saddle Bracket

The joist saddle bracket is designed to support the EPS insulation to the correct depth below the plates. They are fitted over the joist at 500mm centres and at each insulation joint.

Please avoid air infiltration at the end of joist runs, as this will seriously affect the heat transfer.



**When using the Diffusion Plate system on joists spaced greater than 400mm centres, joists must be overbattened at 90° to the joist run and spaced at 400mm centres. Battens should be 25mm x 50mm and fixed flat onto the joists. With this method, compressible insulation may be looped over the joists, to replace the 25mm EPS 70 and joist saddle brackets. If diffusion plates are to be used on ground floor joist insulation levels should be increased to meet current building regulations.**

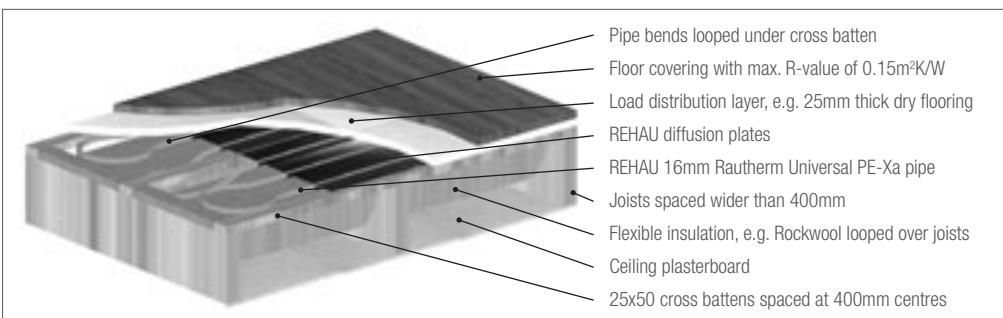

# 5. DIFFUSION PLATE SYSTEM INSTALLATION INSTRUCTIONS



1



2



3



4

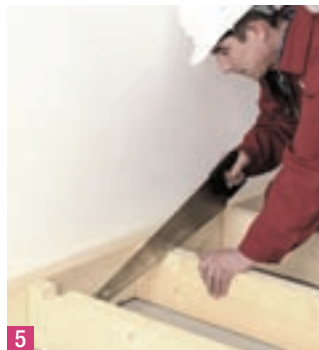

5



6

**Step 1** - Make sure site requirements for installing underfloor heating are met: rooms cleared, installation area dry, sealed to the elements.

**Step 2** - Fit the joist saddle brackets over the joists at 500mm spacings.

**Step 3** - Cut the 25mm EPS 70 insulation and fit it tightly between the joists, covering the whole floor area.



**To minimise air infiltration use compressible insulation material to block up any gaps at the end of each joist run.**

**Step 4** - Identify the quantity of plates for the area from the underfloor heating design. Distribute the plates evenly over the area ensuring that:

- A minimum gap of 100mm between the plates (lengthways)

- Plates are kept at least 500mm from the end of the joist to allow for pipe bends

- Plates are fitted with a slight upward camber, to ensure good contact with the flooring

- Each plate is fixed with 6 staples.

**Step 5** - Notching of joists should be carried out according to the current building regulations:

( $>0.07 \times \text{span from support}$ ,  $<0.25 \times \text{span from support}$ , not deeper than  $0.125 \times \text{depth of joist}$ ).

When passing a pipe through a joist notch, it is recommended that precautions should be taken to allow for expansion, contraction and free movement of the pipe (see below).

**Step 6** - Fix manifold to wall or into cabinet and fix retaining rail.

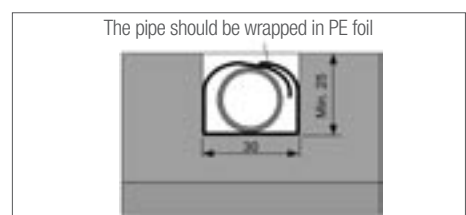

**IMPORTANT**  
Notches are deep enough and lined

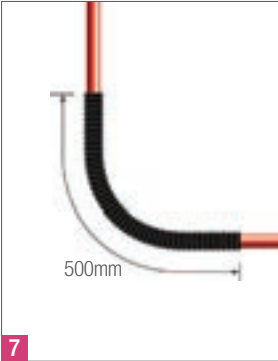

7



8



9



10

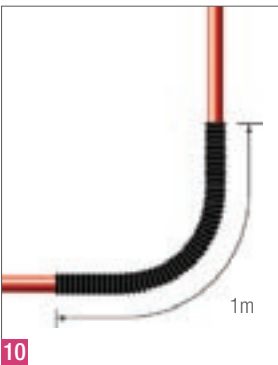

10



11



12

**Step 7** - Cut a short piece of corrugated sleeve (at least 0.5m long) and slide it over the pipe end. Sleeve is to protect pipe from shearing where it enters the floor structure.

**Step 8** - Connect REHAU RAUTHERM pipe to the manifold using REHAU pipe connecting unions.

**Step 9** - Start laying the circuit by simply “snapping” the pipe into the plates. The circuit is laid in the single meander pattern as per the underfloor heating design.

When installing pipe in door frames or holes through walls, always put on a section of corrugated sleeving in this area to allow free movement of pipe. Sleeving can be split along the length and clipped over the pipe.

**Step 10** - Before connecting return to manifold, slide on another 0.5m long corrugated sleeve section.

**Step 11** - Install the remaining circuits in the same manner, as detailed in steps 7 to 10.

**Step 12** - Lay the final floor covering at 90° to the plates.



**For Health and Safety issues, under no circumstances should any other trades enter the room, before the final floor decking is placed.**



**IMPORTANT**  
Plates to be fitted with a slight upward camber

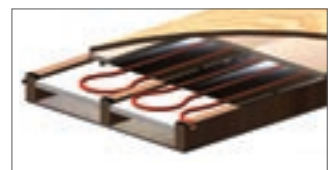

**IMPORTANT**  
For joists spaced wider than 400mm

### Component Selection Table

Components	16mm RAUTHERM Art. No. 136430	20mm RAUTHERM Art. No. 136450	Average Quantity per m <sup>2</sup>
<b>2 Channel Plate</b> Art. No. 249075	Y	N	1.6
<b>3 Channel Plate</b> Art. No. 249095	Y	N	1.6
<b>2 Channel 1/2 Plate</b> Art. No. 249085	Y	N	3.15
<b>Joist Saddle Bracket</b> Art. No. 249065	Y	N	9
<b>EPS 70 Insulation</b> Art. No. 264195	Y	N	0.35

### Technical Data

	2 Channel Plate Art. No. 249075	3 Channel Plate Art. No. 249095	2 Channel 1/2 Plate Art. No. 249085
<b>Size</b>	1000mm x 380mm	1000mm x 380mm	500mm x 380mm
<b>Thickness</b>	0.8mm	0.8mm	0.8mm
<b>Material</b>	Aluminium	Aluminium	Aluminium
<b>Conductivity</b>	160 W/mK	160 W/mK	160 W/mK
<b>Pipe Spacing</b>	200mm	120mm	200mm

### Typical Floor Structure

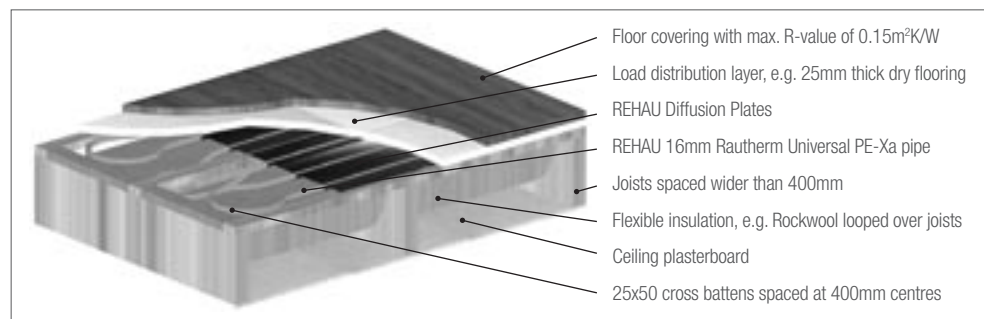
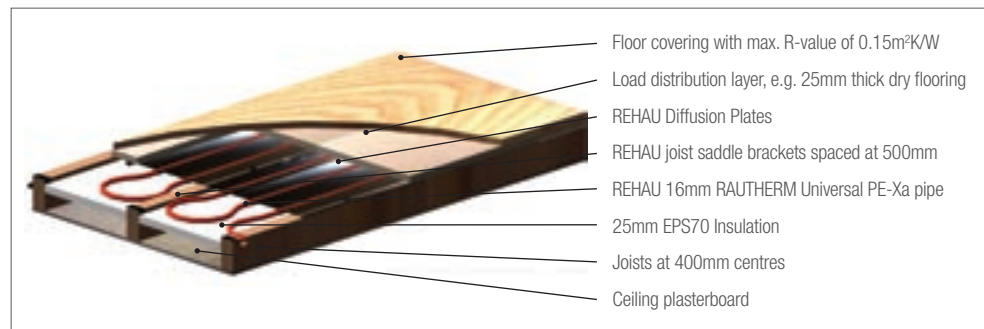

## 5. FLOATING FLOOR SYSTEM



This dry system is ideal for installations where a finished floor is required within a minimum time frame. No wet trades are involved, making it a very fast system to install and removes the need for other building trades.

The REHAU Floating Floor system is suitable for domestic as well as commercial applications. For domestic applications this can be chipboard or plywood, for commercial installations we recommend 25mm thick dry flooring elements.

Extruded polystyrene panels are pre-routed in different patterns and are laminated with a strong aluminium foil. The foil diffuses the heat uniformly across the entire floor surface, the response time is significantly reduced compared to traditional wet screed systems due to the lower thermal mass.

Floating Floor installations using the single meander pattern are possible on both solid and suspended substrates.

The REHAU Floating Floor system utilises the REHAU RAUTHERM Universal pipe 20mm x 1.9mm.

**Because the heat transfer of this system is different to a standard screed system, standard design software such as HT2000 cannot be used.**

# 5. FLOATING FLOOR SYSTEM

## COMPONENT DESCRIPTION

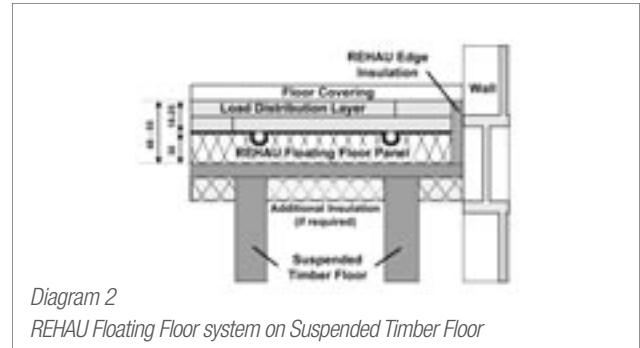
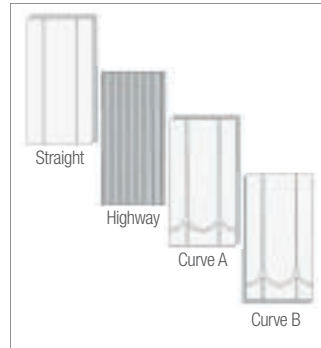

Diagram 2  
REHAU Floating Floor system on Suspended Timber Floor

All floating floor panels are made from extruded Polystyrene XPS. Each panel features a rebate to create an interlocking floor. They are supplied in a standard size of 1.25m (L) x 0.6m (W) x 30mm (H) and are available in four variants:-

- Straight Panel (foil faced)
- Highway Panel (no foil)
- Curve A Panel (foil faced)
- Curve B Panel (foil faced).

Highway panels are used for all connecting lengths of pipe and to connect the pipework to the manifold.

### Floor Preparation

The ground must be sufficiently level before the system is installed. To overcome unlevel ground a dry levelling compound can be placed onto REHAU PE membrane followed by a 10mm dry flooring element (see diagram 1). This provides a clean solution without the introduction of any wet trades and can compensate for differences in floor height of up to 60mm.

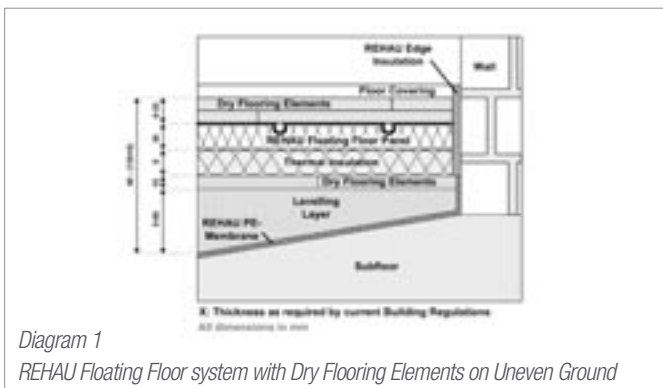

Diagram 1  
REHAU Floating Floor system with Dry Flooring Elements on Uneven Ground

When installing the system onto a suspended timber floor, ensure the floor structure is solid enough to withstand the intended load without deflecting or flexing. Check the structural integrity of the floor and make any defects good (i.e screw down all loose floorboards). (See diagram 2).

### Distribution Layer

To distribute the intended loads uniformly across the Floating Floor panels, a distribution layer must be laid. For domestic applications this can be chipboard or plywood, for commercial applications it is recommended using 25mm Dry Flooring Elements, which are glued together at the joints to create a uniform floor (See flooring manufacturers guidelines). For commercial applications with higher traffic loads, a second layer of 10mm Dry Flooring Elements can be bonded on top (see flooring manufacturers guidelines). (See diagram 3 for orientation of layers).

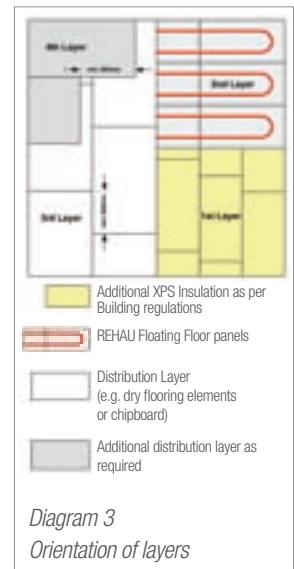

Diagram 3  
Orientation of layers

### Additional Insulation

To meet current Building Regulations, some installations may require additional insulation. Extra insulation panels can be laid underneath the floating floor panels at a 90° angle. However, it is important to check that the insulation is suitable for the intended point loads (see diagram 3 for orientation of layers).

### REHAU Routing Tool

The REHAU routing tool allows easy and quick customisation of panels. It is mains operated and features a hot blade specially shaped to cut the correct groove into the Floating Floor panels. Its size makes it the ideal solution for tight pipe bends and where grooves have to be cut close to a wall or corners.



# 5. FLOATING FLOOR SYSTEM INSTALLATION INSTRUCTIONS

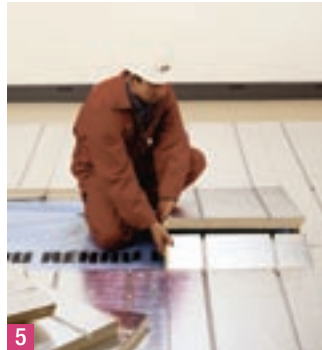
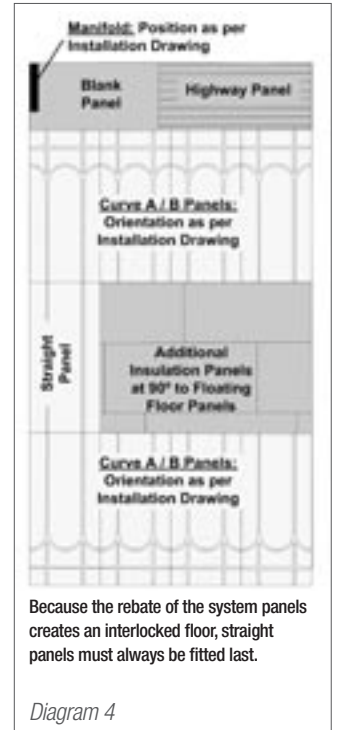
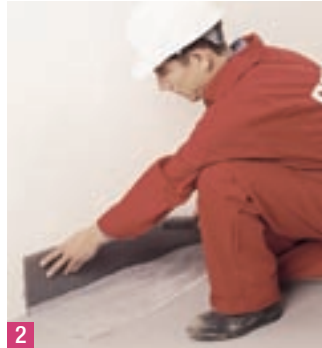

**Step 1** - Make sure site requirements for installing underfloor heating are met: rooms cleared, installation area dry, sealed to the elements, flat even floor, and surface free of irregularities.

**Step 2** - REHAU edge insulation must be fitted if using Dry Flooring Elements. It is not required with chipboard or plywood flooring panels. However, using edge insulation can assist in eliminating sound bridging.

Fit REHAU edge insulation around the perimeter and internal walls, columns, drains and door frames ensuring a 50mm overlap at joints (insulation already comes with self adhesive tape on the back).

**Step 3** - REHAU polyethylene membrane must be used if Dry Flooring Elements are being used on concrete as a substrate:

- The membranes overlap each other by 200mm and should be sealed
- The adhesive tape from the foil on the edge insulation is securely fixed to the membrane.

**Step 4** - Lay additional insulation (if required) as follows:

- The longest side of the panel is laid at a 90° angle to the Floating Floor panels
- Stagger the joints as in a brick wall
- Insulation boards are butted tightly up against each other.

**Step 5** - Lay REHAU Floating Floor Panels ensuring the following (see diagram 4):

- Always lay one insulation panel or highway panel underneath the manifold
- Use highway panels along the shortest wall for all connecting lengths
- **Always lay curved A & B first**
- Next lay straight panels. Trim as required using the REHAU insulation cutter.

**Step 6** - Mark on all Floating Floor panels where additional grooves are required (see diagram 3 for details). Then route the grooves into the panels using the REHAU routing tool or an industrial router with suitable vacuum cleaner.

# 5. FLOATING FLOOR SYSTEM INSTALLATION INSTRUCTIONS



7

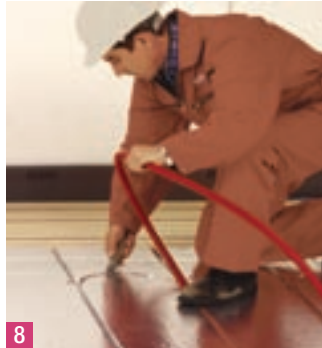

8



9

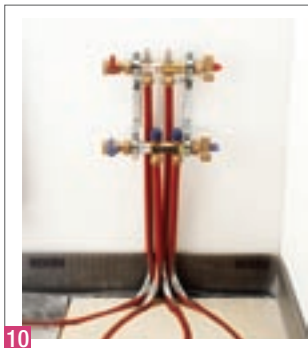

10

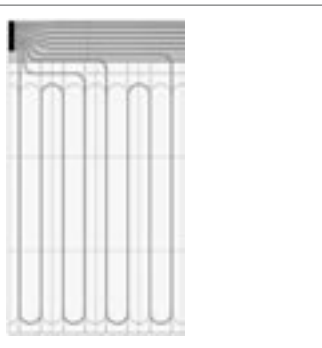

11

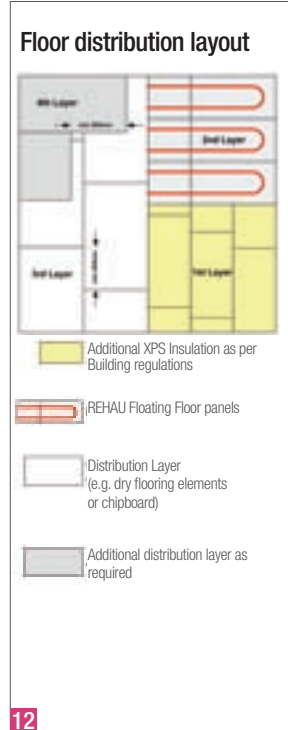

12

**Step 7** - Fix manifold to the wall or into the cabinet. Fit the pipe bend former in the corner where pipe enters the Floating Floor panel, allowing for enough pipe to reach the manifold. Alternatively, corrugated sleeve with retaining rail can be used. Connect REHAU RAUTHERM pipe to the manifold using REHAU pipe connecting unions.

**Step 8** - Push pipe into the grooves of the Floating Floor panels following the single meander pattern. Use a sharp knife to cut the foil over the bends (or the REHAU insulation cutter).

**Step 9** - Cut the return pipe ensuring there is enough pipe to connect to the manifold. Ensure the pipe forms a tight bend to the wall. Fit the pipe bend former or

corrugated sleeve on to the pipe where it exits the Floating Floor and connect to the manifold using REHAU pipe connecting unions.

**Step 10** - Install remaining circuits as detailed in steps 7 to 9.

**Note: A pressure test must be carried out first before continuing with steps 11 & 12.**

**Step 11** - Fit load distribution layer at 90° to the Floating Floor panels and follow manufacturer's guidelines.

**Step 12** - Lay the final floor covering making sure the surface of the distribution layer has been prepared according to manufacturer's guidelines.



**IMPORTANT**  
Always fit pipe bend formers



**IMPORTANT**  
Each layer is orientated at 90° to layer below

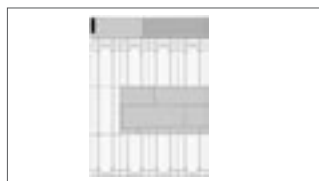

**IMPORTANT**  
Position Curve Panels first before fitting Straight Panels

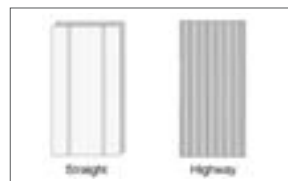

**IMPORTANT**  
Watch out for rebate on system panels

## Component Selection Table

Components	16mm RAUTHERM Pipe Art. No. 136430	20mm RAUTHERM Pipe Art. No. 136450	Average Quantity
<b>Straight Panel</b> Art. No. 234439	N	Y	1.33 panels per m <sup>2</sup>
<b>Curve A Panel</b> Art. No. 234440	N	Y	1.33 panels per m <sup>2</sup>
<b>Curve B Panel</b> Art. No. 234450	N	Y	1.33 panels per m <sup>2</sup>
<b>Highway Panel</b> Art. No. 234459	N	Y	1.33 panels per m <sup>2</sup>
<b>Blank Panel</b> Art. No. 234619	N	Y	1.33 panels per m <sup>2</sup>
<b>Pipe Bend Former</b> Art. No. 258798	N	Y	2 piece per circuit
<b>Edge Insulation</b> Art. No. 264411	N	Y	Length of perimeter
<b>Polyethylene Membrane</b> Art. No. 256054	N	Y	1.3m per m <sup>2</sup>
<b>Floor Insulation Cutter</b> Art. No. 249632	N	Y	-
<b>Routing Tool</b> Art. No. 249682	N	Y	-
<b>Corrugated Sleeve</b> Art. No. 137150	N	Y	1m per manifold port

## Technical Data

	Panel Type				
	Straight	Curve A	Curve B	Highway	Blank
REHAU Art. No.	234439	234440	234450	234459	234619
Dimensions in mm (Length x Width x Thickness)	1250x600x30	1250x600x30	1250x600x30	1250x600x30	1250x600x30
Foil faced	Y	Y	Y	N	N
Thermal conductivity	0.029 W/mK	0.029 W/mK	0.029 W/mK	0.029 W/mK	0.029 W/mK
Compression strength	300 kPa	300 kPa	300 kPa	300 kPa	300 kPa
Density	> 30kg/m <sup>3</sup>	> 30kg/m <sup>3</sup>	> 30kg/m <sup>3</sup>	> 30kg/m <sup>3</sup>	> 30kg/m <sup>3</sup>
Fire class	Euroclass E	Euroclass E	Euroclass E	Euroclass E	Euroclass E
Grade classification to BS EN 13164	Designation code to EN 13164 TI - CS (10/Y) 300 - CC (2/1.5/50) 110 WL (Y) 0.7 - WD (V) 3 - FT2 - DS (TH) - DLT (2) 5				

## Typical Floor Structure

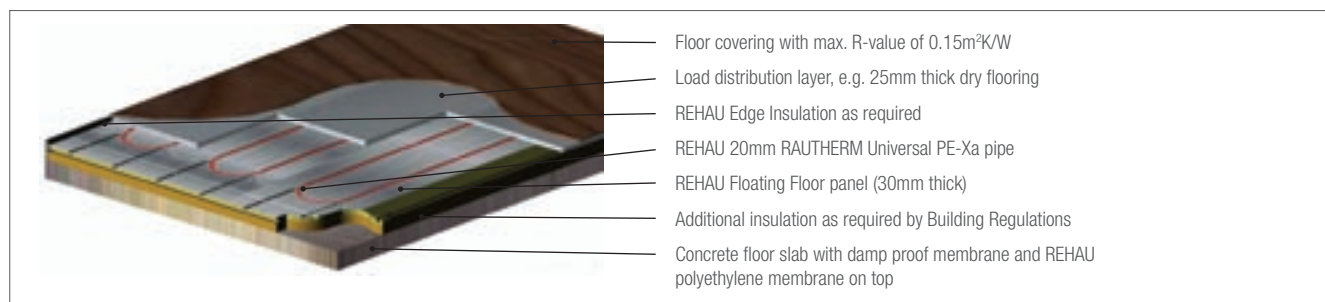

## 5. SPRUNG FLOOR SYSTEM



The REHAU Sprung Floor system is used for impact resilient floors, which are predominantly used for physical activities, such as sports halls, dance studios, leisure centres, squash courts, etc. To achieve the best performance from the system, it is recommended to use a high quality flooring system, e.g. Junckers BluBat Sports Floor System (batten size 48x50mm).

When installing the REHAU Sprung Floor system in a room which is required for a multitude of uses, the installation must be carefully assessed as the required design temperatures of 20°C to 21°C can result in extended response times.

The underfloor heating pipes are not fixed in any way to the sprung floor structure. This ensures the unique performance characteristics of the sprung floor are preserved. It also means that the benefits of a REHAU underfloor heating system can be enjoyed without having to compromise on the sprung floor effects.

Each underfloor heating circuit is laid in the double meander pattern with all heating circuits installed parallel to each other. This simplifies the hydraulic fine-tuning of the complete system during commissioning.

The REHAU Sprung Floor system utilises a matrix of REHAU RAUTHERM Universal pipe 20mm x 1.9mm within an air chamber formed between the floor surface, the flooring joists and the insulation layer beneath the pipes.

Due to the construction of the REHAU Sprung Floor system, it is possible to use it with other raised sports floor systems.

**Due to the heat transfer of the REHAU Sprung Floor system, standard design software such as HT2000 cannot be used.**



**If new era type floor are to be used please contact sales office.**

# 5. SPRUNG FLOOR SYSTEM

## COMPONENT DESCRIPTION

### RAUFIX Rail

The RAUFIX rail is manufactured from Polypropylene and its unique pipe clip design makes it ideal for the 20mm REHAU RAUTHERM Universal pipe.

REHAU also offer another pipe clipping rail, the Railfix system, which can also be used (see page 38).

The function of the rail is to secure the underfloor heating circuits in the planned pattern.

RAUFIX rails are supplied in 1m lengths and must be cut down to fit between the joists of the sprung floor. The rails should be spaced at 400mm centres.

### Staples

To secure the RAUFIX rails to the insulation, 40mm staples should be pushed in through the rail at alternating angles. The staples should also be used to fix the pipe close to where it passes through the notched joists.

### Insulation

To achieve the best performance a minimum of 25mm thick high performance insulation is required beneath the pipes. To meet current Building Regulations some installations may require extra insulation.



**Some sports floor systems are limited in height, e.g. Junckers BluBat Sports Floor System - 48mm total), which means that only 25mm thick insulation can be installed above the concrete substrate. In such circumstances, any additional thermal insulation required must be fitted underneath the substrate.**

### Floor Preparation

The substrate must be sufficiently flat and smooth. Typical requirements require no gaps of more than 3mm under a 3m straight edge.

(Please refer to flooring manufacturer's guidelines).

A moisture barrier is installed to prevent moisture rising into the wood structure when the underfloor heating is in operation. (See flooring manufacturer's guidelines for exact specification).



RAUFIX Rail

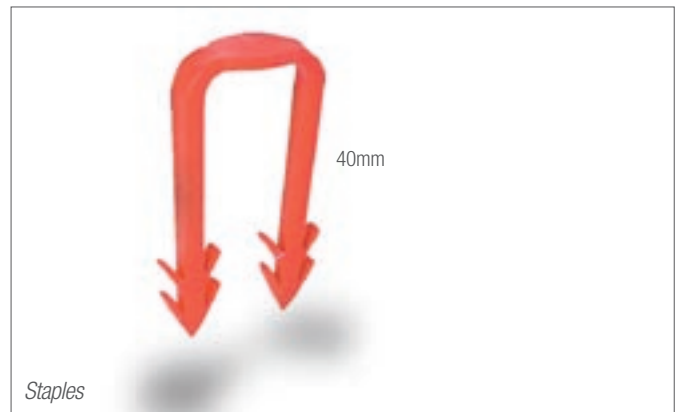

Staples

# 5. SPRUNG FLOOR SYSTEM

## INSTALLATION INSTRUCTIONS

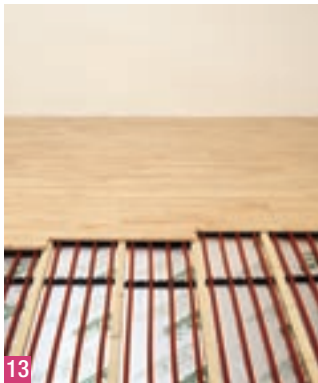
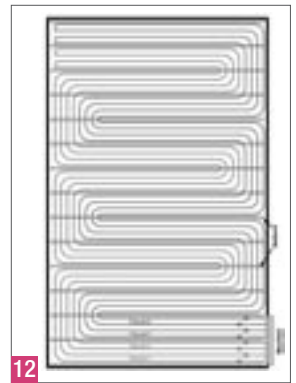
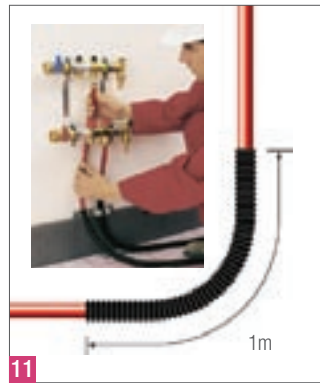
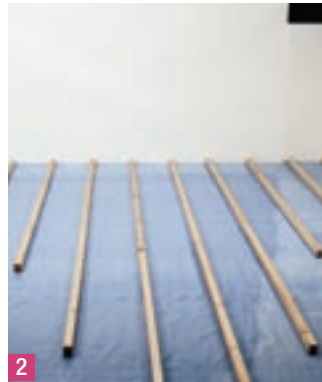
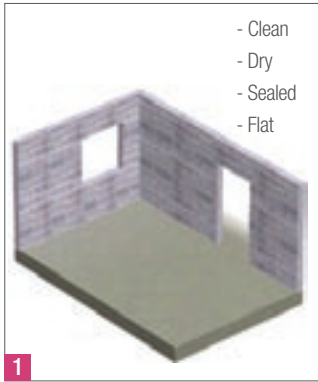

**i** Installation shown for BLUBAT floor systems only. For other floor systems please contact the sales office.

**Step 1** - Make sure site requirements for installing underfloor heating are met: space cleared, installation area dry, sealed to elements, flat even floor and a surface free of irregularities. In addition, check all requirements specified by the flooring manufacturer are also met. These typically include specific humidity levels and maximum residual moisture contents for concrete (or screed) subfloors and wooden based subfloors.

**Step 2** - The moisture barrier and battens should be laid as per installation instructions issued by the flooring manufacturer. As standard moisture barriers are overlapped by 200mm and battens spaced at 411mm centres with a reduced spacing close to the walls. Batten joints must not be even but staggered as much as possible. (See flooring manufacturers guidelines).

**Step 3** - Lay insulation between the battens (BluBat only) ensuring the following:

- Insulation boards are trimmed to fit between the battens
- All boards are butted tightly up against each other and to the battens
- The specified spacing of battens remain unchanged.

**Step 4** - Notch the battens ensuring that:

- You have identified the correct locations on the installation drawing
- No notch is directly below a tongue and groove joint on the floorboards and their fixings. The notches should be spaced to the width of the floor boards
- All notches are sufficiently deep to prevent the pipe from touching the floor boards
- Every notch is lined with a thin polyethylene foil which can be wrapped over the pipe.

**Step 5** - Fix RAUFIX rails to the insulation using at least 2 red staples per rail. Rails must be laid at 0.4m centres and about 0.5m from the first notch.

**Step 6** - Fix manifold to wall or into cabinet and fix retaining rail underneath. Please refer to section 3 of this guide for further details.

**Step 7** - Cut a short piece of corrugated sleeve (at least 1m long) and slide it over the pipe end. The sleeve is to protect the pipe when it passes through the wall or floor into the sports hall.

**Step 8** - Connect the REHAU RAUTHERM Universal pipe to the manifold using REHAU pipe connecting unions.

**Step 9** - Start laying the circuit by simply “snapping” the pipe into the RAUFIX rails. Circuits are laid in the double meander pattern as per the underfloor heating installation drawing.

**Step 10** - Where the pipe passes through a notch ensure the pipe is laid with as little twist as possible (light bulb shape). Secure the pipe with additional red staples on both sides of the notch and fold the PE lining over the pipe.

**Step 11** - Before connecting the return to the manifold, slide on another 1m long corrugated sleeve.

**Step 12** - Install remaining circuits in the same way as detailed in steps 7 to 11.

**Step 13** - Lay the floor boards according to the instructions of the flooring manufacturer.

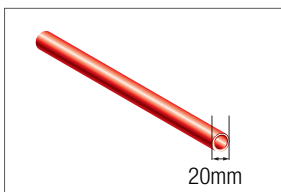

**IMPORTANT**  
Use 20mm pipe only!



**IMPORTANT**  
Pipe bends are laid in light bulb shape

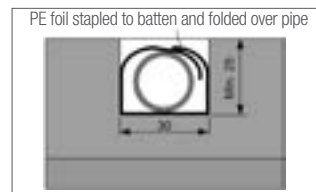

**IMPORTANT**  
Notches are deep enough and lined

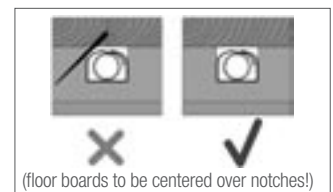

**IMPORTANT**  
All tongue & groove joints and portanails must be clear of notches

### Component Selection Table

Components	16mm RAUTHERM Pipe Art. No. 136430	20mm RAUTHERM Pipe Art. No. 136450	Average Quantity
<b>RAUFIX Rail</b> Art. No. 240241	N	Y	1.5m per m <sup>2</sup> floor
<b>Railfix Rail</b> Art. No. 259258	N	Y	1.5m per m <sup>2</sup> floor
<b>RAUFIX Staples</b> Art. No. 268118, 40mm	N	Y	8 pieces per m <sup>2</sup> floor
<b>Polyethylene Membrane</b> Art. No. 256054	N	Y	1.3m per m <sup>2</sup> floor

### Technical Data

	<b>RAUFIX Rail</b> Art. No. 240241	<b>Railfix Rail</b> Art. No. 259258	<b>RAUFIX Staple</b> Art. No. 268118	<b>Polyethylene Membrane</b> Art. No. 256054
<b>Size</b>	1000mm x 50mm x 40mm	50mm x 20mm	40mm x 20mm	1200mm x 0.2mm x 100m
<b>Material</b>	Polypropylene (PP)	PVC		Polyethylene (PE)
<b>Weight</b>	0.224kg	0.35kg/m	0.001kg	29kg / 100m
<b>Colour</b>	Black	Grey	Red	Clear

### Typical Floor Structure

